

Binary input



BIP-4-KNX-REG

Operation manual / application description

90406

All device data can also be found here:



<https://beg-luxomat.com/qr.php?prtno=90406>

© 2022

B.E.G. Brück Electronic GmbH
Gerberstraße 33
51789 Lindlar
GERMANY

Telefon: +49 (0) 2266 90121-0

Fax: +49 (0) 2266 90121-50

E-Mail: info@beg.de

Internet: beg-luxomat.com

1	About this document	7
1.1	Applicable documents	7
1.2	Means of representation used	7
1.3	Prerequisites for understanding	7
2	Security	8
2.1	Intended use	8
2.2	Foreseeable misuse	8
2.3	Qualified persons / qualified electricians	9
2.3.1	Qualified electricians	9
2.4	Disclaimer	9
3	General	10
3.1	Basic information about the KNX bus	10
3.2	Symbolism	10
4	Functional description	11
4.1	Product catalogue	11
4.2	Application	11
4.3	Device structure	12
5	Mounting and electrical connection	13
5.1	Mounting the device	13
5.2	Connecting the device	14
5.3	KNX connection	15
6	Commissioning	16
6.1	Carry out ETS commissioning	16
6.2	KNX Programming mode	17
6.3	Manual operation and status display	17
7	Reset to factory device settings	18
8	General settings	19
8.1	Device name (30 characters)	19
8.2	Send delay after bus power return	19
8.3	Prog. mode on device front	19
8.4	Manual operation on device	19
8.5	Heartbeat	20
8.6	Long button press after	20
8.7	LED visualisation top/bottom	20
9	Input A1: General	21

9.1	Name (30 characters)	21
9.2	Function	21
10	Function „Switching, Dimming, Shutter, Send value, Scene“	22
10.1	Type	22
10.2	Lock function	22
11	Input A1: Lock function	23
11.1	Polarity of object	23
11.2	Behaviour of (...) on start	23
11.3	Behaviour of (...) at end	23
12	Function „Impulse counter“	24
12.1	Input signal	24
12.2	Count on	24
12.3	Scaled counter (e.g. [kWh])	24
12.4	Rate of change (e.g. [kW], [m/s], [km/h])	24
13	Input A1: Switching	25
13.1	User control	25
13.2	Function of (...) on press / short press Function of (...) on release / long press	25
13.3	Output b	25
14	Input A1: Switching – State query	26
14.1	User control: Press / Release	26
15	Input A1: Dimming	27
15.1	Dimming function	27
16	Input A1: Shutter	28
16.1	Shutter function	28
16.2	User control	28
17	Input A1: Send value	29
18	Input A1: Scene	30
18.1	Scene position 1 - 8	30
18.2	Reset scene position	30
18.3	Condition on long/very long button press	30
19	Input A1: Scaled counter	32
19.1	Scaling factor (Value per pulse)	32

19.2	Datapoint type	32
19.3	Send condition	32
19.4	Monitoring limit value	33
19.5	Limit value	33
19.6	Behaviour on reaching limit value (object)	33
19.7	Behaviour on reaching limit value (counter)	33
19.8	Send on device restart	33
19.9	Reset via object	33
19.10	Reset after ETS download	33
19.11	Lock function	34
20	Input A1: Lock function	35
20.1	Polarity of object	35
20.2	Behaviour on start of lock	35
20.3	Behaviour on end of lock	35
21	Input A1: Rate of change	36
21.1	Scaling factor (Value per delta in base time span)	36
21.2	Time base	36
21.3	Measurement time span	36
21.4	Datapoint type	36
21.5	Send condition	36
21.6	Monitoring limit value	37
21.7	Limit value	37
21.8	Behaviour on exceeding limit value	37
21.9	Behaviour on going below limit value	37
22	Logic / Timer	39
22.1	Function 1 - 16	39
23	Function 1 - 16 (Timer)	40
23.1	Function name (10 characters)	40
23.2	Timer type (Switch-on delay)	40
23.3	Timer type (Switch-off delay)	40
23.4	Timer type (Switch-on and -off delay)	40
23.5	Timer type (Impulse (Staircase))	40
24	Function 1 - 16 (Logic)	42
24.1	Function name (10 characters)	42
25	Care, maintenance and disposal	43
25.1	Cleaning	43

25.2 Maintenance 43

25.3 Disposal 43

26 Diagnosis / Troubleshooting 44

27 Service / Support 45

 27.1 Manufacturer's warranty 45

 27.1.1 Product code 45

 27.2 Contact details 45

28 Technical data 46

 28.1 General data 46

 28.2 Dimensioned drawing BIP-4-KNX REG 47

29 Declaration of Conformity 48

 29.1 EU Declaration of Conformity 48

 29.2 UK Declaration of Conformity 48





1 About this document

1.1 Applicable documents

Brief operating instructions

90406M1_Short_MAN_BIP-4-KNX-REG_90406_de_uk_fr_nl_V2 (enclosed with the device).

1.2 Means of representation used

	Symbol for danger to life due to electric shock
	Symbol for possible danger to persons
	Symbol for possible property damage
	Symbol for useful information and tips
NOTE	Signal word for possible property damage
CAUTION	Signal word for possible minor injuries
WARNING	Signal word for possible serious injuries
DANGER	Signal word for possible fatal injuries

1.3 Prerequisites for understanding

NOTE	
	KNX knowledge To understand this application description, a KNX commissioning or project planning course (ETS 5) is required.

2 Security

The BIP-4-KNX REG has been developed, manufactured and tested in compliance with the applicable safety standards. It corresponds to the state of the art.

2.1 Intended use

The device is a device for controlling electronic ballasts with DALI interface via the KNX bus system. It is mounted on a top-hat rail according to EN 60715 in the sub-distribution board.

CAUTION



Observe the intended use!

The protection of operating personnel and the device is not guaranteed if the device is not used in accordance with its intended use.

- Only use the device in accordance with its intended use.
- B.E.G. Brück Electronic GmbH is not liable for damage caused by improper use.
- Read these operating instructions before commissioning the device. Knowledge of the operating instructions is part of the intended use.

NOTE



Comply with rules and regulations!

- Observe the locally applicable legal regulations and the regulations of the employers' liability insurance associations.

WARNING



Work on electrical installations may only be carried out by qualified electricians or by instructed persons under the direction and supervision of a qualified electrician in accordance with the electrotechnical regulations.

Danger due to electric shock.

Device is not to be used to isolate other equipment from the mains supply.

Danger due to electric shock.

- Before working on the device or replacing lamps, disconnect the mains voltage and switch off the circuit breaker.

2.2 Foreseeable misuse

Any use other than that specified under „Intended use“ or any use going beyond that is considered improper use. The use of the device is not permitted in the following cases in particular:

- in rooms with explosive atmospheres
- in safety-relevant circuits
- for medical purposes

NOTE



Do not tamper with or modify the device!

- Do not modify or alter the device in any way. Interventions and modifications to the device are not permitted.
- The device must not be opened. It does not contain any parts to be adjusted or maintained by the user.
- Repairs may only be carried out by B.E.G. Brück Electronic GmbH.

2.3 Qualified persons / qualified electricians

Connection, assembly, commissioning and adjustment of the device may only be carried out by competent persons.

Requirements for competent persons:

- You have suitable technical training.
- You know the rules and regulations on occupational health and safety.
- You know the operating instructions for the device.
- You were instructed by the person in charge in the installation and operation of the device.

2.3.1 Qualified electricians

Work on electrical installations may only be carried out by qualified electricians or by instructed persons under the direction and supervision of a qualified electrician in accordance with the electrotechnical regulations.

Due to their professional training, knowledge and experience as well as knowledge of the relevant standards and regulations, skilled electricians are able to carry out work on electrical installations and to recognise possible hazards independently.

In Germany, qualified electricians must comply with the provisions of the accident prevention regulation DGUV Vorschrift 3 (e.g. master electrician). In other countries, corresponding regulations apply and must be observed.

2.4 Disclaimer

B.E.G. Brück Electronic GmbH is not liable in the following cases:

- The device is not being used as intended.
- Reasonably foreseeable misapplications are not taken into account.
- Assembly and electrical connection are not carried out competently.
- Changes (e.g. structural) are made to the device.

3 General



3.1 Basic information about the KNX bus

A KNX commissioning or project planning course is required to understand these instructions.

In order to work with the B.E.G. application, it must first be imported into the ETS. ETS version 5 or higher is supported.

3.2 Symbolism

In the following application description, various symbols are used for a better overview. These symbols are explained briefly here.

	This symbol indicates text passages that must be read in order to avoid errors during project planning and commissioning.
	This symbol indicates parameter settings that experience has shown to lead to optimal use of the device.

4 Functional description

4.1 Product catalogue

Manufacturer: B.E.G.
Product name: BIP-4-KNX REG
Product group: Binary inputs
Order no. 90406

4.2 Application

The device is a compact binary input with 4 channels to control lights, shutter etc. with conventional switches or contacts. Inputs are designed for dry contacts.

Two push buttons and three LEDs allow a local operation and a visualisation of the device state.

In addition to the input channels the device includes 16 independent functions for logic or timer control.

4.3 Device structure

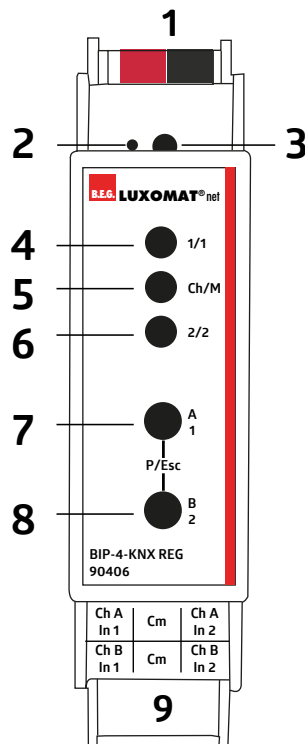

Fig. 1

1	KNX bus connector
2	KNX programming LED
3	KNX button for programming mode
4	LED multicolour 1/1
5	LED multicolour Ch/M
6	LED multicolour 2/2
7	Button A1
8	Button B2
9	Pluggable screw terminals

5 Mounting and electrical connection

WARNING



Work on electrical installations may only be carried out by qualified electricians or by instructed persons under the direction and supervision of a qualified electrician in accordance with the electrotechnical regulations.

Disconnect the cable from the power supply before installation!
This device is not to be used to isolate other equipment from the mains supply.
Observe KNX installation guidelines!

DANGER



Danger to life due to electric shock!
Electric shock can cause death.
Before working on the device, isolate the device from the mains supply and cover live parts in the vicinity!

5.1 Mounting the device

→ Mounting in the sub-distribution (sub-distribution board)

→ Snaps onto top-hat rail according to EN 60715.

The screw terminals for the mains connection should be on top.

NOTE



Observe temperature range and ensure sufficient cooling if necessary.

When operating power devices/actuators in a sub-distribution, keep a distance of 1 HP, approx. 18 mm, between the devices to avoid overheating.

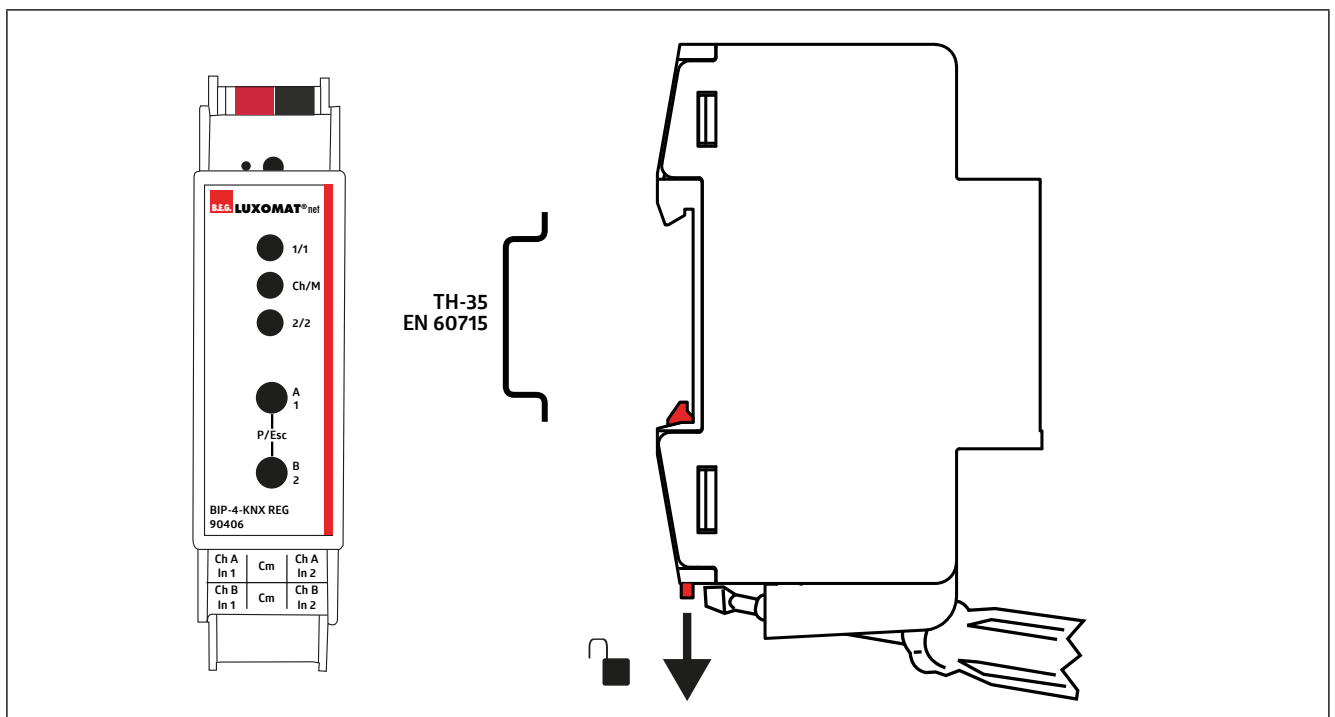

5.2 Connecting the device

DANGER



Electric shock when touching live parts.
Electric shock can cause death.
Before working on the device, isolate the device from the mains supply and cover live parts in the vicinity!

CAUTION



Service connection!
The RJ45 connection on the underside of the device, which is fitted with a blind plug, is for service purposes only!

Make the KNX bus connection and the connection of the power supply according to the following connection diagram.

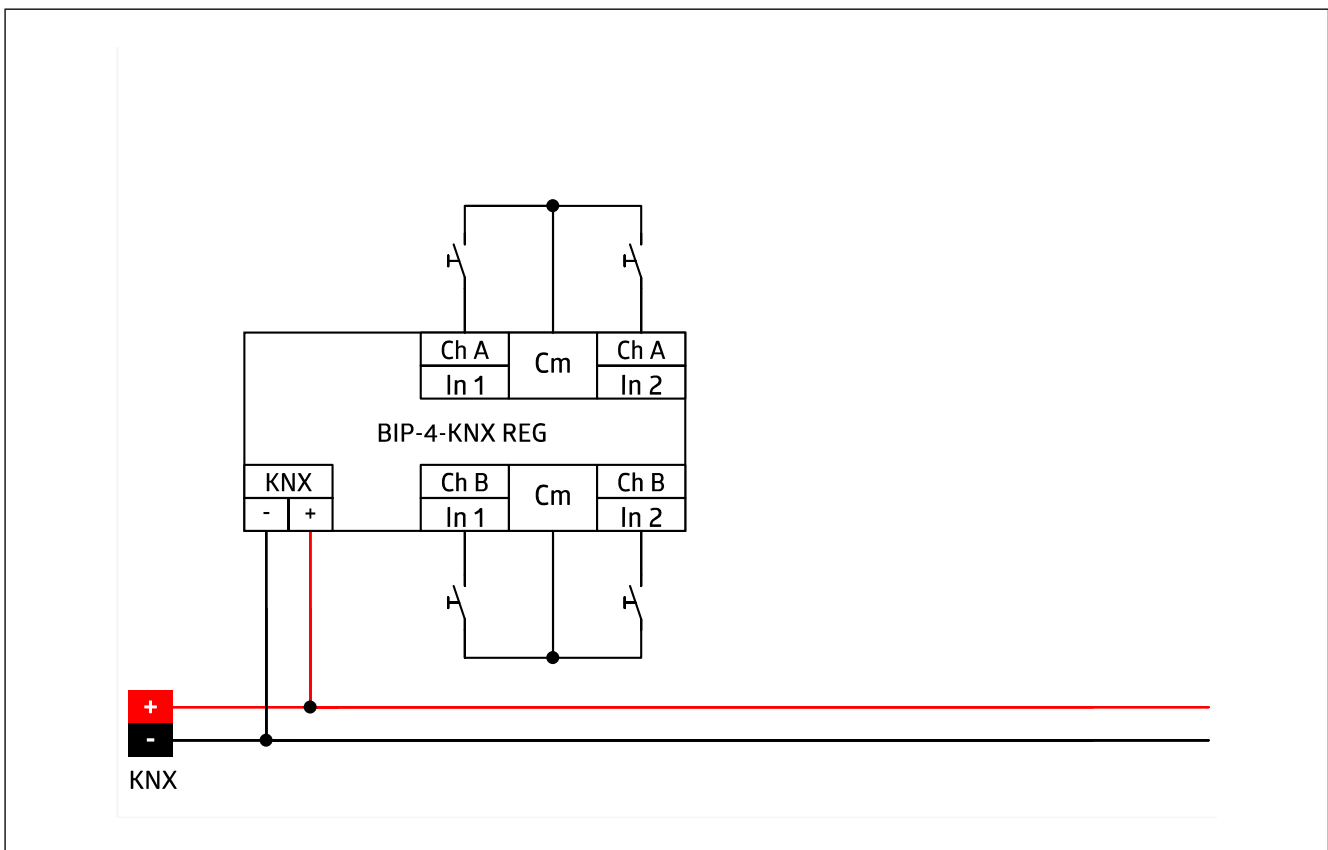

5.3 KNX connection

CAUTION**Observe KNX installation regulations!**

This device complies with the KNX guidelines. Detailed knowledge of the KNX system is required for commissioning.

Cover cap KNX bus terminal

To protect the bus connection from dangerous voltages in the connection area, a cover cap must be fitted. The cap is fitted with the bus terminal attached and the bus line connected and routed to the rear.

Put on the cover cap

- Guide the bus line to the rear.
- Put the cover cap over the bus terminal and press it down.

Remove cover cap

- Press the cover cap upwards and pull it off.

6 Commissioning

After mounting the device and connecting the bus line, the device can be put into operation. The following procedure is generally recommended.

6.1 Carry out ETS commissioning

Switch on the voltage supply of the device.

In order to work with the device, the product database must first be imported into the ETS

NOTE



ETS from version 5.

ETS version 5 or higher is supported.

→ Download the product database of the device from the B.E.G. website.

→ Import the downloaded product database of the device into the ETS.

You can now configure the BIP-4-KNX REG in your project.

6.2 KNX Programming mode

The KNX programming mode is activated/deactivated either by pressing the flushed KNX programming button **3** or by simultaneously pressing the buttons **7** and **8**.

When the programming mode is active, the programming LED **2** and LED Ch/M **5** light red. See “4.3 Device structure” on page 8.

6.3 Manual operation and status display

The LED Ch/M **5** lights up or flashes if the device is successfully powered by the KNX bus.

By pressing button A1 **7** long, the manual operation mode will be entered for channel pair A (Ch A In1/In2). This is indicated by cyclic single flashing of LED Ch/M **5** in orange.

By pressing button B2 **8** long, the manual operation mode will be entered for channel pair B (Ch B In1/In2). This is indicated by cyclic double flashing of LED Ch/M **5** in orange.

If manual operation of a channel pair is activated, the bus telegrams of In1 and In2 can be triggered by button A1 **7** and B2 **5** von In2 ausgelöst werden, if input channel is configured by ETS.

LED 1/1 **4** and LED 2/2 **6** are used to indicate state of selected channel pair while manual operation. They light green when the button A1 **7** or B2 **8** is pressed.

Summary of the states of LED Ch/M **5**:

LED Status	Meaning
LED lights green	Device is working in standard operation mode.
LED lights red	Programming mode is active.
LED flashes 1x orange	Programming mode is not active. Manual operation is active: Switching first channel pair (Ch A In1/In2)
LED flashes 2x orange	Programming mode is not active. Manual operation is active: Switching first channel pair (Ch B In1/In2)
LED blinks red	Programming mode is not active. Manual operation is not active. The device is not properly loaded e.g. after an interrupted download .
LED blinks green	The device is currently loaded by the ETS.

7 Reset to factory device settings

It is possible to reset the device to its factory settings:

- Disconnect the KNX Bus connector **1** from device
- Press the KNX programming button **3** and keep it pressed down
- Reconnect the KNX Bus connector **1** of device
- Keep the KNX programming button **3** pressed for at least another 6 seconds
- A short flashing of all LEDs (**2 4 5 6**) visualises the successful reset of the device to factory default settings.

See “4.3 Device structure” on page 8.

8 General settings

8.1 Device name (30 characters)

An arbitrary name can be assigned for the device. The device name should be meaningful, e.g. „Living Room“. This helps the clarity of the ETS project.

General settings	
Device name	... [max. 30 characters]

8.2 Send delay after bus power return

A send delay of telegrams after the return of the bus voltage can be set via this parameter. In this case, telegrams from the device are sent to the KNX bus in a delayed manner by the set time. This results in a reduction of the bus load at a bus power return. Other functions such as receiving telegrams or query of the inputs are not affected by this parameter.

General settings	
Send delay after bus power return	... [5 s]

8.3 Prog. mode on device front

In addition to the normal programming button **3** the device allows activating the programming mode on the device front without opening the switchboard cover. The programming mode can be activated and deactivated via pressing simultaneously both buttons **7** and **8**.

This feature can be enabled and disabled via the parameter “Prog. mode on device front”. The recessed programming button **3** (next to the Programming LED **2**) is always enabled and not influenced by this parameter.

General settings	
Prog. mode on device front	Disabled
	Enabled

8.4 Manual operation on device

This parameter is used to configure the manual operation on the device. The manual operation mode can be disabled or activated (with or without time limitation). The time limit defines the duration until the automatic return from the manual operation mode back into the normal operating mode.

The device is in normal operating mode when the manual control is not active. In the manual operating mode, received switching telegrams are ignored. When the manual operation mode is terminated (after expiry of the time limit or manually by pressing both buttons **7** and **8**), the next telegram is sent on state change of the inputs.

General settings	
Manual operation on device	Disabled
	Enabled with time limit 1 min.
	Enabled with time limit 10 min.
	Enabled with time limit 30 min.
	Enabled without time limit

8.5 Heartbeat

Cyclic sending of values to the KNX-Bus, to indicate that the device is operational. For the Cycle time values between 1 min and 24h are selectable.

General settings	
Heartbeat	Disabled
	Enabled

Group Object	Type KNX	Size	Direction
GO 1 Heartbeat - Trigger	1.001	1 Bit	To KNX

Furthermore, the parameters Heartbeat and Cycle time are used as configuration for cyclic sending, in case that switching is configured as state query. For a more detailed description regarding state query please take a look at "Input A1: Switching – State query".

8.6 Long button press after

The time for detection of a long button press can be set here, this time is valid for all input channels.

General settings	
Long button press after	... [1,2 s]

8.7 LED visualisation top/bottom

Here the operating mode of the LEDs **4** and **6** in normal operation can be set, it is selectable:

General settings	
LED visualisation top/bottom	Disabled (<i>LED is disabled always.</i>)
	Channel A1 (<i>LED top</i>)
	Channel A2 (<i>LED bottom</i>)
	Channel B1
	Channel B2 (<i>LED indicates the state of the connected contact at the selected input 9..</i>)
	Via group object (<i>LED is operated only via group object.</i>)

9 Input A1: General

9.1 Name (30 characters)

An arbitrary name can be assigned for the channel. However, this should be clear and meaningful, this makes it easier to work with the associated group objects, because the given name is displayed there as a label. If no name is assigned, the group objects are named "Input ..." with the channel number, which is also used in this manual. The 1st channel will be described below, the functioning of the other 3 channels is according to the 1st.

Input A1: General	
Name (30 characters)	... [Input A1]

9.2 Function

This parameter defines the functionality of the connected contact. The following options are selectable:

Input A1: General	
Name (30 characters)	Disabled
	Switching
	Dimming
	Shutter
	Send value
	Scene
	Impulse counter

A more detailed description of the functions can be found in the individual function descriptions.

10 Function „Switching, Dimming, Shutter, Send value, Scene“

If an input function of a channel is selected, the following parameters are displayed:

10.1 Type

The mode of operation of the contact connected to the input channel can be configured here:

Input A1: General	
Type	Normally open contact
	Normally closed contact

10.2 Lock function

With this parameter the lock function can be enabled. If this functionality is activated, the associated group objects as well as the parameter page “Input A1: Lock function” are displayed for further configuration. If the lock has been activated via the group object, no telegrams are triggered by state changes of the connected contact.

Input A1: General	
Lock function	Disabled
	Enabled

Group Object	Type KNX	Size	Direction
GO 16 Input A1: Lock - Activate	1.001	1 Bit	From KNX

11 Input A1: Lock function

11.1 Polarity of object

This parameter defines, if the lock should be activated by receiving a 1 or by receiving a 0. The opposite telegram deactivates the lock again.

Input A1: Lock function	
Polarity of object	Lock active on 1
	Lock active on 0

11.2 Behaviour of (...) on start

The telegram can be configured here, which is sent when the lock is activated.

11.3 Behaviour of (...) at end

The telegram can be configured here, which is sent when the lock is deactivated.

12 Function „Impulse counter“

If the impulse counter function is selected, further parameters are displayed in the general settings of the input channel. Here, the general settings of the impulse counter are made, a scaled counter and/or counter of the rate of change must also be selected.

12.1 Input signal

Here it can be selected whether DC or alternating voltage is applied to the binary input.

12.2 Count on

This parameter can be used to determine whether the value of the counter is increased at the rising or falling edge at the input

12.3 Scaled counter (e.g. [kWh])

Here, the scaled counter can be activated, the parameter page „Scaled counter“ is displayed when activated.

12.4 Rate of change (e.g. [kW], [m/s], [km/h])

The counter for a rate of change can be activated here. If activated, the „Rate of change“ parameter page is displayed.

13 Input A1: Switching

If the switching function is selected, up to 2 binary switching telegrams can be sent via the following objects:

Group Object	Type KNX	Size	Direction
GO 11 Input A1: Output a – Switch	1.001	1 Bit	To KNX
GO 12 Input A1: Output b – Switch	1.001	1 Bit	To KNX

Output b is only visible when activated by parameter.

13.1 User control

The parameter “User control” determines whether telegrams are sent when the input is changed (e.g. key switches) or when the input is operated short/long (e.g. switching/dimming switches).

13.2 Function of (...) on press / short press Function of (...) on release / long press

It is selectable for each object, which telegram is sent on opening/closing the contact or on short/long button press.

Input A1: Switching	
Lock function	No reaction
	Switch on
	Switch off
	Toggle

13.3 Output b

Here you can show/hide the parameters and the object for output b.

14 Input A1: Switching – State query

The state query function is used, for example, to monitor window contacts.

The state query mode is recognized automatically by the firmware, if the following parameter setting is configured:

14.1 User control: Press / Release

User control: Press / Release	
Function of (...) on press	Switch on
	Switch off
Function of (...) on release (inverted)	Switch on
	Switch off

If a state query is configured, the value on the object is kept up to date. The value corresponding to the current state is read. If the lock is active, the object value corresponds to the last state before the lock or to the configured value on lock. Cyclic sending of this actual value is possible. Via activating the parameter Heartbeat on page General settings the object value of the state query is sent cyclically on the KNX bus (see Heartbeat), but not if the lock is activated. The cycle time is also used from the corresponding parameter of the heartbeat.

15 Input A1: Dimming

On selection of function Dimming following objects are visible:

Group Object	Type KNX	Size	Direction
GO 11 Input A1: Dimming on/off – Switch	1.001	1 Bit	To KNX
GO 12 Input A1: Dimming relative – Brighter/ Darker	3.007	4 Bit	To KNX

15.1 Dimming function

The dimming function parameter determines whether only one switching / dimming direction or 1-button control is to be used:

Input A1: Dimming	
Dimming function	On / Dim brighter
	Off / Dim darker
	Toggle direction

If the input detects a short button press, a switching telegram is sent via object 11. On long button press, a relative dimming is sent over the entire dimming range to object 12. When releasing after long button press, a dimming-stop telegram is sent via object 12.

The time for detection of a long button press can be set in the general parameters and is valid for all channels.

16 Input A1: Shutter

On selection of Shutter function following objects are visible:

Group Object	Type KNX	Size	Direction
GO 11 Input A1: Drive start – Up/Down	1.001	1 Bit	To KNX
GO 12 Input A1: Drive stop – Step/Stop	1.001	1 Bit	To KNX

16.1 Shutter function

The “Shutter function” parameter determines whether only one shutter direction or 1-button control is to be used:

Input A1: Shutter	
Shutter function	Up / Step-Stop
	Down / Step-Stop
	Toggle direction

16.2 User control

The parameter “User control” determines the sending of telegrams on short and long button press:

Input A1: Shutter	
User control	Long = Drive / Short = Step/Stop <i>Long button press: Drive command via object 11.</i> <i>Short button press: Stop/step command via object 12</i>
	Short = Drive / Short = Step/Stop <i>Alternately drive command via object 11 and stop/step command via object 12 on short button press, long button press is not evaluated</i>
	Pressed = Drive / Release = Stop <i>On button press drive command via object 11, on releasing the button stop/step command via object 12</i>

The time for detection of a long button press can be set in the general parameters and is valid for all channels.

17 Input A1: Send value

If function Send value is selected, the following telegrams can be sent at button press:

1 byte - Percent value

Group Object	Type KNX	Size	Direction
GO 11 Input A1: Send percent value (1 byte) – Set value	5.001	1 Byte	To KNX

1 byte - Integer value

Group Object	Type KNX	Size	Direction
GO 11 Input A1: Send integer value (1 byte) – Set value	5.010	1 Byte	To KNX

2 byte - Integer value

Group Object	Type KNX	Size	Direction
GO 11 Input A1: Send integer value (2 byte) – Set value	7.001	2 Byte	To KNX

2 byte - Float value

Group Object	Type KNX	Size	Direction
GO 11 Input A1: Send float value (2 byte) – Set value	9.001	2 Byte	To KNX

3 byte - RGB value

Group Object	Type KNX	Size	Direction
GO 11 Input A1: Send RGB color value (3 byte) – Set value	232.600	3 Byte	To KNX

14 byte - ASCII string

Group Object	Type KNX	Size	Direction
GO 11 Input A1: Send ASCII string (14 byte) – Set value	16.000	14 Byte	To KNX

Shutter

Group Object	Type KNX	Size	Direction
GO 11 Input A1: Send blind position – Set position	5.001	1 Byte	To KNX
GO 12 Input A1: Send slat position – Set position	5.001	1 Byte	To KNX

A field for entering the values to be sent is displayed, as well as the objects appropriate to the selected type. If the shutter is selected as the value to be sent, height is sent on button press, lamella is sent on releasing the button, if the respective value is used.

18 Input A1: Scene

On selection of Scene function the following object is visible:

Group Object	Type KNX	Size	Direction
GO 11 Input A1: Scene - Scene control	18.001	1 Byte	To KNX

18.1 Scene position 1 - 8

For each position, scene 1 – 64 can be activated.

If only one scene position is activated, it is sent on short button press.

If several scene positions are used, the activated positions are switched through with each short button press.

18.2 Reset scene position

The behavior for selection and transmission of the scene positions can be determined via the parameter “Reset scene position”:

Input A1: Scene	
Reset scene position	Never
	After execution
	5 Sec. - 10 Min.

Never

Starting with the first scene position, the next scene position of the list is sent with each short button press, after the last scene position has been sent, the list starts again from the beginning.

After execution

Beginning with the first scene position, each short button press switches the scene position by one position within the execution delay, at the end of the execution delay, the current scene position is sent

5 Sec. - 10 Min.

On each button press the configured delay time is started.

Starting with the first scene position, the next scene position of the list is sent with each short button press, after the last scene position has been sent, the list starts again from the beginning.

After the delay time has expired, the list starts again at the first scene position on the next short button press.

When the lock function is used, the scene position is always reset when unlocking.

18.3 Condition on long/very long button press

It is also possible to select how a long and very long button press is to be treated:

Input A1: Scene	
Condition on long/very long button press	No reaction
	Save last scene
	Send scene
	Reset position

Save last scene

A telegram for “save scene” with the last sent scene is triggered.

Send scene

The scene configured in the appearing parameter is sent.

Reset position

This function is used to override the behavior as set in the “Reset scene position” parameter.

The duration of time for detecting a very long button press is twice the time for detecting a long button press, as it is parameterised in the general settings.

19 Input A1: Scaled counter

This counter can be used to count values on input impulses, where an integer value or a floating-point value can be selected as a counter variable. With this function, e.g. Electrical energy can be counted directly and sent to the bus via an object.

19.1 Scaling factor (Value per pulse)

Here, a floating-point value is to be entered. It determines the value by which the counter value is increased per pulse.

19.2 Datapoint type

The datapoint type of output object of the counter variable can be selected here:

Integer (32 Bit) – DPT 13

Group Object	Type KNX	Size	Direction
GO 11 Input A1: Counter – Value	13.013	4 Byte	To KNX

Float (16 Bit) – DPT 9

Group Object	Type KNX	Size	Direction
GO 11 Input A1: Counter – Value	9.024	2 Byte	To KNX

Float (32 Bit) - DPT 14

Group Object	Type KNX	Size	Direction
GO 11 Input A1: Counter – Value	14.056	4 Byte	To KNX

19.3 Send condition

This parameter can be used to determine how the current counter value is to be sent:

Input A1: Scaled counter					
Send condition	<table border="1"> <tr> <td>On read</td> </tr> <tr> <td>On change</td> </tr> <tr> <td>Cyclically</td> </tr> <tr> <td>On change and cyclically</td> </tr> </table>	On read	On change	Cyclically	On change and cyclically
On read					
On change					
Cyclically					
On change and cyclically					

On read

No independent sending of the counter value by the device. To read the counter value, the read-flag of the group object has to be set.

On change

An additional parameter is displayed to select the minimal delta from the last sent value for sending a new counter value.

Cyclically

An additional parameter is displayed to configure the sending frequency of the counter variable.

On change and cyclically

Both sending conditions are active.

If the counter is locked by the object, also cyclic sending is stopped.

19.4 Monitoring limit value

When limit monitoring is activated, the following object is displayed:

Group Object	Type KNX	Size	Direction
GO 12 Input A1: Counter threshold – State	1.002	1 Bit	To KNX

When limit monitoring is activated, the following parameters are displayed:

19.5 Limit value

Here you can edit the checked limit value. The datapoint type is the same as the counter value.

19.6 Behaviour on reaching limit value (object)

Here it is possible to determine whether a 0 or a 1 is sent via the object “Counter threshold – State” when the limit value is reached.

19.7 Behaviour on reaching limit value (counter)

In addition to the limit value itself, it is possible to determine the behavior of the counter when the limit value is reached:

Input A1: Scaled counter	
Behaviour on reaching limit value (counter)	Counter continue
	Counter reset and continue
	Counter stop

Counter continue

Counter value continues increasing on ever pulse

Counter reset and continue

Counter value is reset to 0 and continues increasing on ever pulse.

Counter stop

Counter value stays on limit value and must be reset by object.

19.8 Send on device restart

It can be determined with this parameter whether the counter value should be sent when the device is restarted.

19.9 Reset via object

If this function is activated, the following object appears:

Group Object	Type KNX	Size	Direction
GO 15 Input A1: Reset – Trigger	1.017	1 Bit	From KNX

When a telegram is received via this object, the current count values are reset to 0.

19.10 Reset after ETS download

If this parameter is activated, the counter values are reset to 0 after device reset (e.g. after ETS download), otherwise they are retained.

19.11 Lock function

The lock function can be activated or deactivated here. If this functionality is activated, the following group object appears, as well as the parameter page „Lock function“ for detailed configuration.

Group Object	Type KNX	Size	Direction
GO 16 Input A1: Lock – Activate	1.001	1 Bit	From KNX

20 Input A1: Lock function

20.1 Polarity of object

This parameter can be used to determine how the lock is to be activated, either by receiving a 1 or a 0. The corresponding telegram disables the lock again.

20.2 Behaviour on start of lock

With this parameter the behavior of the counter can be configured when the lock is activated:

Input A1: Lock function	
Behaviour on start of lock	Counter stop
	Counter stop and reset

20.3 Behaviour on end of lock

With this parameter the behavior of the counter can be configured when the lock is deactivated:

Input A1: Lock function	
Behaviour on end of lock	Counter continue
	Counter reset and continue

21 Input A1: Rate of change

This counter is used to connect devices to the bus where the rate of change is critical within a time interval, e.g. an anemometer.

21.1 Scaling factor (Value per delta in base time span)

A floating-point value is to be entered here. It determines the value by which the counter value is increased on every pulse

21.2 Time base

Here the time base of the rate of change can be specified:

Input A1: Lock function	
Time base	Pulses per second (z.B. [m/s], [km/h]) <i>Value from parameter Scaling factor is multiplied by 1.</i> Pulses per hour (z.B. [kW]) <i>Value from parameter Scaling factor is multiplied by 3600</i>

21.3 Measurement time span

The measurement time span determines how quickly the counter can react to changes. Therefore, a short sample rate should be selected for fast processes (e.g. anemometer).

The rate of change is calculated using the 3 parameters mentioned above:

The device saves several meter readings per measurement interval, scales it with the scaling factor * time base and divides it by the measuring interval.

21.4 Datapoint type

The datapoint type of output object of the counter variable can be selected here:

Floating point (16 Bit) – DPT 9

Group Object	Type KNX	Size	Direction
GO 13 Input A1: Rate of change – Value	9.024	2 Byte	To KNX

Floating point (32 Bit) – DPT 14

Group Object	Type KNX	Size	Direction
GO 13 Input A1: Rate of change – Value	14.056	4 Byte	To KNX

21.5 Send condition

This parameter can be used to determine how the current counter value is to be sent:

Input A1: Rate of change	
Send condition	On read On change Cyclically On change and cyclically

On read

No independent sending of the counter value by the device. To read the counter value, the read-flag of the group object has to be set.

On change

An additional parameter is displayed to select the minimal delta from the last sent value for sending a new counter value.

Cyclically

An additional parameter is displayed to configure the sending frequency of the counter variable.

On change and cyclically

Both sending conditions are active.

21.6 Monitoring limit value

When limit monitoring is activated, the following object is displayed:

Group Object	Type KNX	Size	Direction
GO 14 Input A1: Rate threshold – State	1.002	1 Bit	To KNX

When limit monitoring is activated, the following parameters are displayed:

21.7 Limit value

Here you can edit the checked limit value. The datapoint type is the same as rate of change value.

21.8 Behaviour on exceeding limit value

In addition to the limit value itself, it is possible to determine whether the counter should transmit 0 or 1 via the object if the limit value is exceeded.

21.9 Behaviour on going below limit value

Here it is possible to determine whether the counter should transmit 0 or 1 via the object if the counter variable goes under limit value.

Example: Electricity meter with SO interface

From the data sheet of the electricity meter it can be seen that the device delivers 500 pulses per kWh. A device with constant power of 1kW is connected to this current meter for one hour.

The scaled counter measures the energy consumed:

Scaling factor: $1 / 500 = 0.002$ -> Output in kWh

The counter for the rate of change measures the current power:

Scaling factor:

- Output in kW: $1/500 = 0.002$

- Output in W: $1/500 * 1000 = 2$

Time base: Pulses per hour

Measurement time span: 300 s

Example: Anemometer

From the data sheet of the electricity meter it can be seen that the device delivers 4 pulses/s at a wind speed of 1 m/s.

The counter for the rate of change measures the wind speed:

Scaling factor:

- Output in m/s: $1/4 = 0.25$

- Output in km/h: $1/4 * 3.6 = 0.9$

Time base: Pulses per second

Measurement time span: 10 s

22 Logic / Timer

22.1 Function 1 - 16

These channels contain additional functions such as timing and logic. All these 16 additional functions are identical. The following options are selectable:

Logic / Timer	
Function 1 - 16	Disabled
	Timer
	Logic

Function type (Disabled)

If the function type is set to „Disabled“, no timer or logic specific parameters and group objects are available.

Function type (Timer)

The timer-specific parameters and group objects are available.

Function type (Logic)

The logic-specific parameters and group objects are available.

Note: These additional logic and timer functions can be linked to one another by means of the associated group objects. This also allows to create complex structures. For this purpose, the output of a function is set to the same group address as the input of the next function.

23 Function 1 - 16 (Timer)

23.1 Function name (10 characters)

The function name can be chosen freely.

The name is visible in the group object entry in the ETS software. This makes it easier to work with the associated group objects, because the given name is displayed there as a label.

23.2 Timer type (Switch-on delay)

A timer that switches ON after duration defined in 'Delay time [s]' parameter.

The output value can be inverted by parameter 'Output' (Not inverted / Inverted).

Input -----1-----0-----

Output -----|-T-1-----0-----

Group Object	Type KNX	Size	Direction
Timer - Switch-on delayed - Input	1.002	1 Bit	From KNX
Timer - Switch-on delayed - Output	1.002	1 Bit	To KNX

23.3 Timer type (Switch-off delay)

A timer that switches OFF after duration defined in 'Delay time [s]' parameter.

The output value can be inverted by parameter 'Output'. (Not inverted / Inverted)

Input -----1-----0-----

Output -----1-----|-T-0-----

Group Object	Type KNX	Size	Direction
Timer - Switch-off delayed - Input	1.002	1 Bit	From KNX
Timer - Switch-off delayed - Output	1.002	1 Bit	To KNX

23.4 Timer type (Switch-on and -off delay)

A timer that switches ON and OFF after duration defined in 'Delay time [s]' parameter.

The output value can be inverted by parameter 'Output'. (Not inverted / Inverted)

Input -----1-----0-----

Output -----|-T-1-----|-T-0-----

Group Object	Type KNX	Size	Direction
Timer - Switch-on/off delayed - Input	1.002	1 Bit	From KNX
Timer - Switch-on/off delayed - Output	1.002	1 Bit	To KNX

23.5 Timer type (Impulse (Staircase))

Timer with impulse that - after being switched ON - automatically switches OFF after a defined duration defined in 'Delay time [s]' parameter.

The output value can be inverted by parameter 'Output'. (Not inverted / Inverted)

Input -----1-----0-----

Output -----1-T-0-----

Group Object	Type KNX	Size	Direction
Timer - Switch-impulse (staircase) - Input	1.002	1 Bit	From KNX
Timer - Switch-impulse (staircase) - Output	1.002	1 Bit	To KNX

NOTE

Each timer can be stopped by sending the opposite value to its input group object.
For example:
An already started switch on timer can be stopped by sending OFF (0) to its input group object.

24 Function 1 - 16 (Logic)

Group Object	Type KNX	Size	Direction
Logic - Gate input A - Input	1.002	1 Bit	From KNX
Logic - Gate input B - Input	1.002	1 Bit	From KNX
Logic - Gate output - Output	1.002	1 Bit	To KNX

24.1 Function name (10 characters)

The function name can be chosen freely.

The name is visible in the group object entry in the ETS software. This makes it easier to work with the associated group objects, because the given name is displayed there as a label.

Gate type (AND gate)

The output is triggered on (1), if both inputs are switched on (1).

Gate type (OR gate)

The output is triggered on (1), if one or both inputs are switched on (1).

Gate type (XOR gate)

The output is triggered on (1), if the two inputs are not equal.

Gate type (NAND gate)

The output is triggered on (1), if one or both inputs are switched off (0).

Gate type (NOR gate)

The output is triggered on (1), if both inputs are switched off (0).

Gate type (XNOR gate)

The output is triggered on (1), if both inputs are equal.

Gate type (INVERTER)

Input on (1) is converted into output off (0). Input off (0) is converted into output on (1).

Group Object	Type KNX	Size	Direction
Logic - Gate input - Input	1.002	1 Bit	From KNX
Logic - Gate output - Output	1.002	1 Bit	To KNX

25 Care, maintenance and disposal

25.1 Cleaning

As the device is installed protected in the sub-distribution (control cabinet), it does not normally require cleaning. However, if cleaning is necessary, please observe the following instructions.

DANGER	
	Electric shock when touching live parts. Electric shock can cause death. Before working on the device, isolate the device from the mains supply and cover live parts in the vicinity!

If necessary, clean the surface of the device with a soft, lint-free cloth.

NOTE	
	Do not use aggressive cleaners! → Do not use aggressive cleaning agents such as thinner or acetone to clean the device. → Only use a fibre-free cloth for cleaning. → Pointed and hard objects can destroy the device.

25.2 Maintenance

The device does not normally require maintenance by the operator. Repairs to the devices may only be carried out by the manufacturer.

For repairs, contact your responsible B.E.G. Brück Electronic branch or directly B.E.G. Brück Electronic GmbH, Germany.

25.3 Disposal

Observe the nationally applicable regulations for electrotechnical components when disposing of them.

26 Diagnosis / Troubleshooting

NOTE



Diagnosis / troubleshooting via the ETS!

→ For diagnosis / troubleshooting, use the corresponding functions of the ETS, e.g.

- Group monitor
- Bus monitor
- Line scan

27 Service / Support

27.1 Manufacturer's warranty

The company B.E.G. Brück Electronic GmbH grants a warranty in accordance with the warranty conditions, which you can download from the website at <https://www.B.E.G.-luxomat.com/service/downloads/>.

27.1.1 Product code

The product is provided with a product code which enables the product to be traced in the event of a guarantee/complaint.

The product code is lasered on the back of the housing.

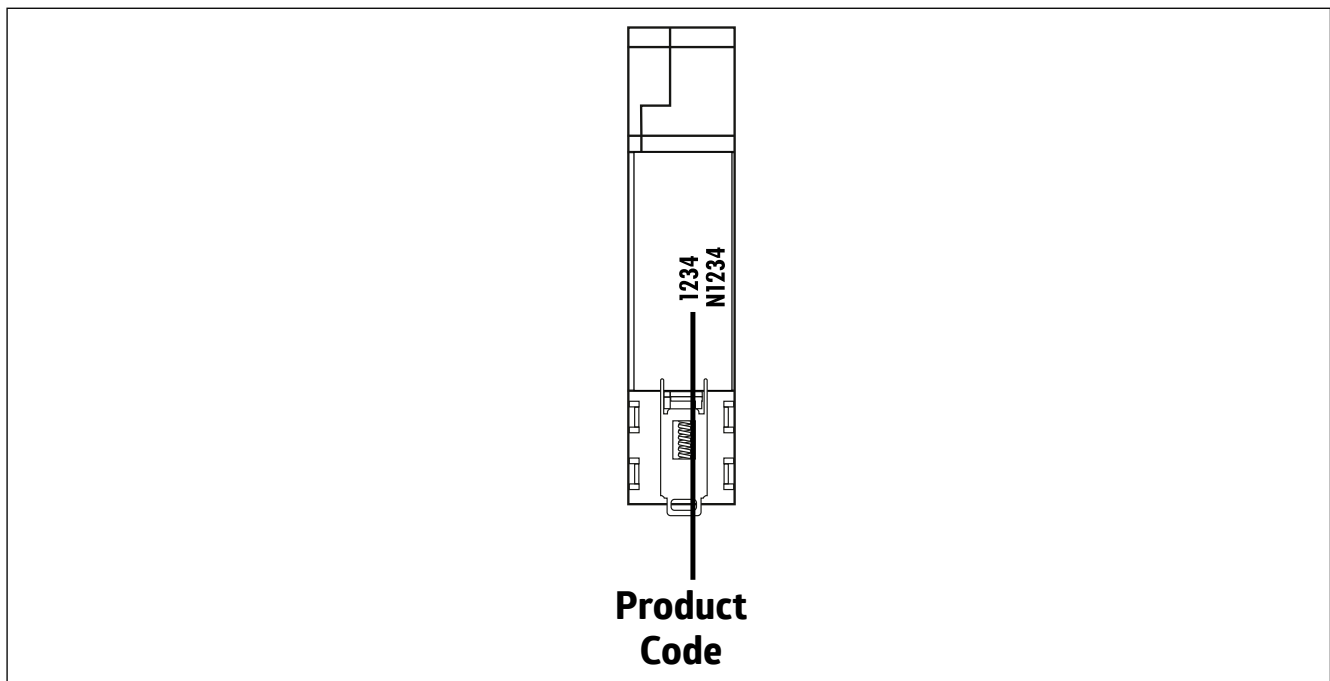

27.2 Contact details

Service hotline:

+49 (0)2266 90121-0

Monday to Thursday 8.00 to 16.00 (UTC+1)

Friday 8.00 to 15.00 (UTC+1)

E-mail:

support@beg.de

Return address for repairs:

Contact your B.E.G. branch or agency.

You can find the contact details at <https://www.beg-luxomat.com/en-in/service/service-points/>.

Or contact directly

B.E.G. Brück Electronic GmbH

Gerberstrasse 33

51789 Lindlar

GERMANY

28 Technical data

28.1 General data

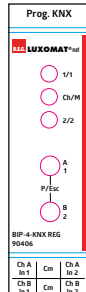
Binary inputs	
Mains voltage	12 - 230 V $\overline{\text{---}}$ ~
Power input binary inputs	< 1 mA
Signal (DC) ticks per second	100
Signal (AC) ticks per second	1
Plug-in screw terminals (3 poles) for binary inputs	Ch A / Ch B
KNX	
Rated voltage KNX	DC 21 ... 32 V SELV
Current consumption KNX	typ. 5,5 mA
KNX connection	Bus terminal red/black
KNX medium	TP256
Mechanical data	
Connection terminals rigid conductors fine-stranded conductors	0.34 - 2.5 mm ² 0.34 - 2.5 mm ²
Mounting on top-hat rail	TH 35 (EN 60715)
Installation width 1 TE	1 TE, 18 mm
Dimensions (H x W x D)	90 x 18 x 64 mm
Housing material	PC
Environmental data	
Ambient temperature	-5 – +45 °C
Storage temperature	-25 – +70 °C
Protection class	IP20
Protection class	II
Operating and display elements	
Operating buttons (KNX)	3
Display elements	3 LEDs mehrfarbig
1 LED red (KNX programming LED)	1
Conformity	
Electromagnetic compatibility	EU Directive 2014/30/EU
Low voltage	EU Directive 2014/35/EU
Restriction of the use of certain hazardous substances in electrical and electronic equipment	EU Directive 2011/65/EU
Nameplate	 <p>The nameplate diagram shows the following connections: - Top: Prog. KNX - Middle: LUXOMAT-net - Below that: Three red circles representing LEDs labeled 1/1, Ch/M, and 2/2. - Below that: Two red circles representing buttons labeled A 1 and B 2. - Bottom: A terminal block with labels Ch A In 1, Ch A In 2, Ch B In 1, and Ch B In 2.</p>

28.2 Dimensioned drawing BIP-4-KNX REG

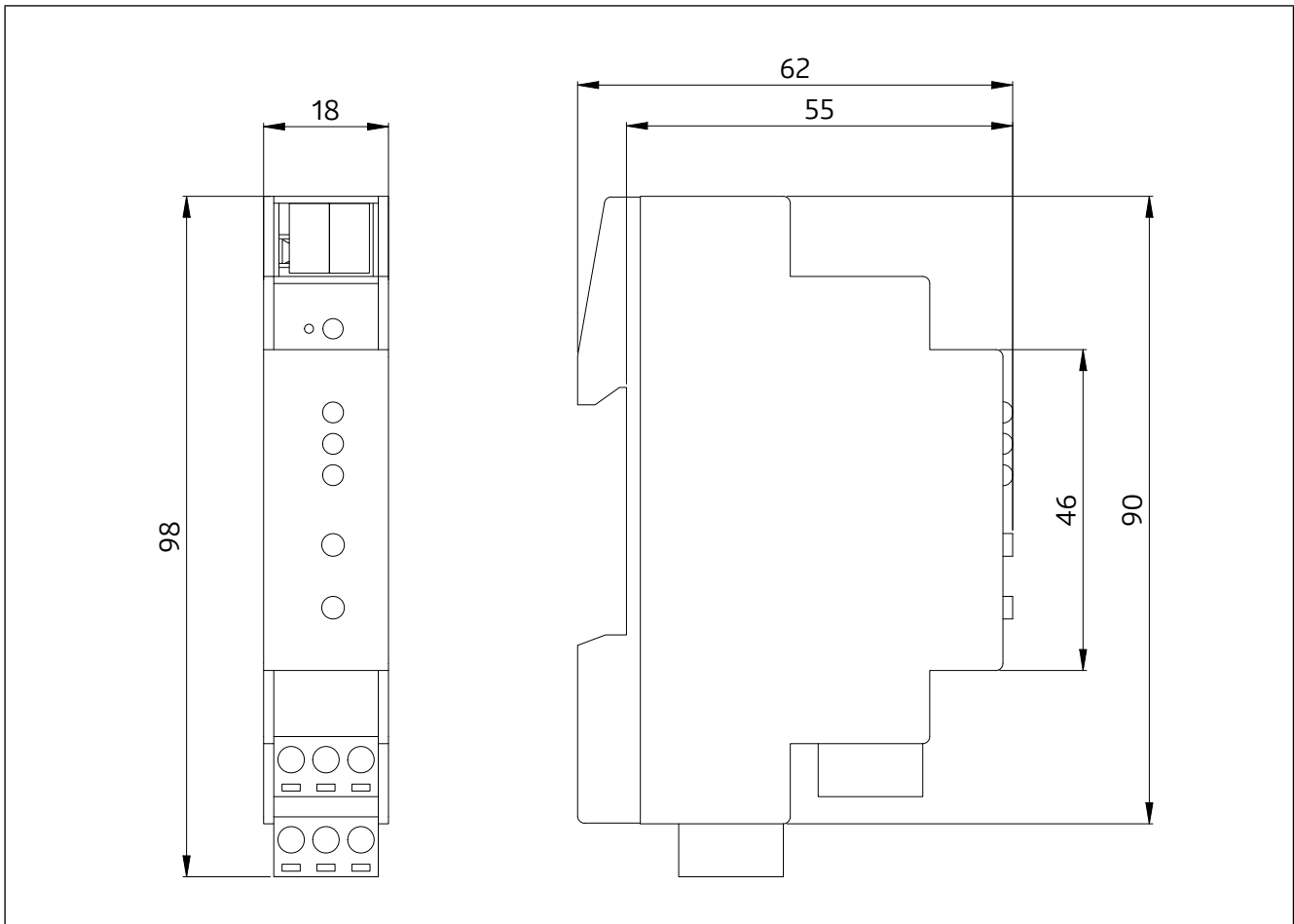

29 Declaration of Conformity

29.1 EU Declaration of Conformity

The product complies with the following EU directives

Electromagnetic compatibility (2014/30/EU)

Low voltage (2014/35/EU)

Restriction of the use of certain hazardous substances in electrical and electronic equipment (2011/65/EU)

NOTE



EU Declaration of Conformity

A detailed EU declaration of conformity can be found at www.beg-luxomat.com or can be requested from the manufacturer.

29.2 UK Declaration of Conformity

This product respects the directives concerning

1. Electrical Equipment Safety Regulation 2016

2. Electromagnetic Compatibility Regulation 2016

3. The Restriction of the Use of Certain Hazardous Substances in Electrical and Electronic Equipment Regulation 2012

Contact:

B.E.G. UK Ltd.

Apex Court – Grove House

Camphill Road

West Byfleet, Surrey KT14 6SQ

Tel: +44 (0) 87 08 50 54 12



B.E.G. Brück Electronic GmbH
Gerberstraße 33
51789 Lindlar

T +49 (0) 2266 90121-0
F +49 (0) 2266 90121-50

info@beg.de
beg-luxomat.com